

DRAWING MADE IN THIRD ANGLE PROJECTION

© COPYRIGHT 1973 BY AMP INCORPORATED, HARRISBURG, PA.
 ALL INTERNATIONAL RIGHTS RESERVED. AMP INCORPORATED PRODUCTS
 COVERED BY U. S. AND FOREIGN PATENTS AND/OR PATENTS PENDING.



SHEET METAL SCREWS NOT SUPPLIED.
 TWO REQUIRED PER CONNECTOR.
 FOR USE WITH 2, 3 & 4 CIRCUIT HOUSINGS WITH A MAXIMUM
 WIRE BUNDLE DIAMETER OF 5/16".

REVISIONS						
P	F	ZONE	LTR	DESCRIPTION	DATE	APPROVED
✓			D	REDRAWN+ADDED 3 VIEW ORTHOGRAPHIC PROJECTION M-5661	2-14-80	MSF/DK
✓			D1	RESTORED	12-7-84	RPH/RS
✓			E	OBSOLETE -2,-3,-4,-5,-6,-7,-8, -9 PER CM-473	4-15-86	KW/RS
✓			F	OBSOLETE -1 PER CM-930	6-6-88	PH/RS
✓			G	REV PER ECN CM-3828	8-3-92	NJG/RS

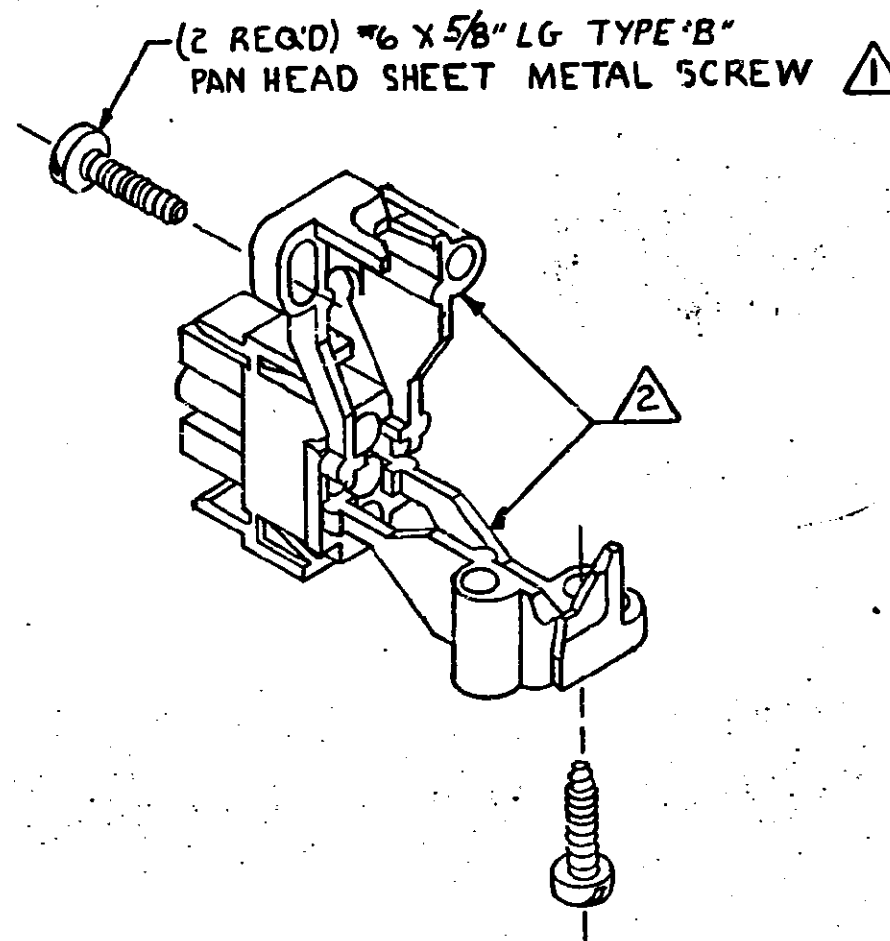
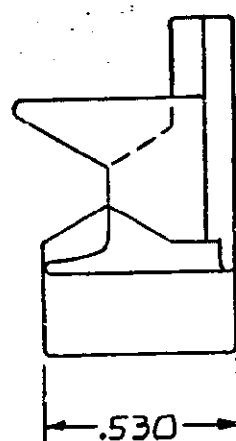
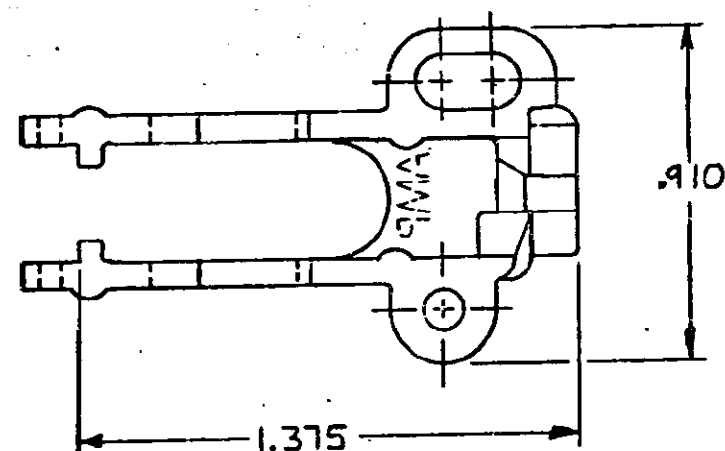
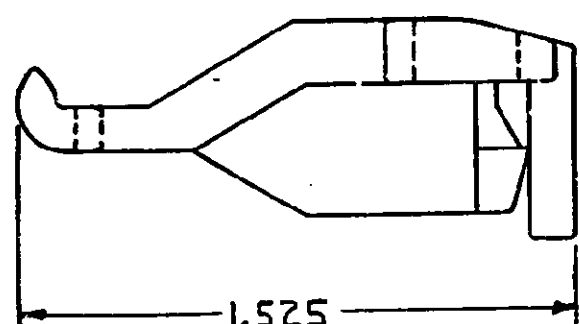

COLOR	MATERIAL	PART NO
NATURAL	NYLON 94 V-2	1-350589-0

UNLESS OTHERWISE SPECIFIED DIMENSIONS ARE IN INCHES. TOLERANCES ON: DECIMALS ± .015 ANGLES ±	CONTRACT NO	AMP INCORPORATED Harrisburg, Pa.		
	CHK	NAME		
	APPD	STRAIN RELIEF FOR UNIVERSAL MATE-N-LOK™ HOUSING		
	APPD	SIZE	CODE IDENT NO	DRAWING NO
MATERIAL	DSGN APPD	C	00779	350589
FINISH	OTHER APPD	SCALE	2-1	SHEET
SEE TABLE				
SEE TABLE				

CUSTOMER DRAWING

350589